

Cerlic CBX

The optical Sludge Blanket Meter
– that works

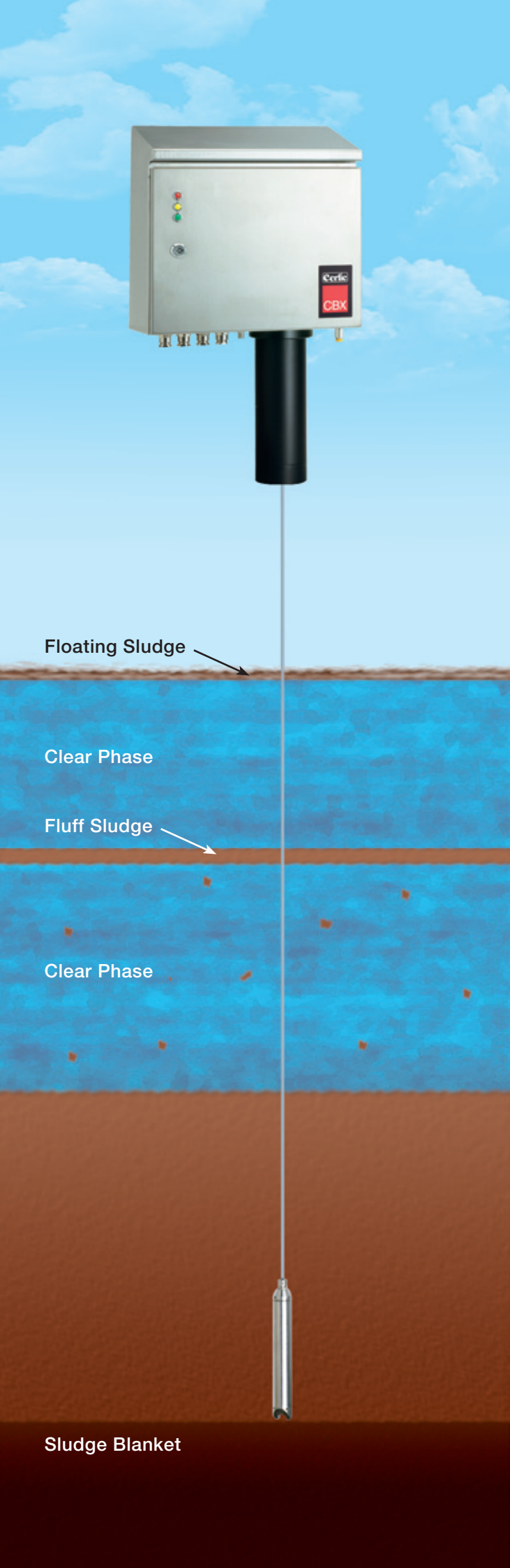

 **Cerlic**
for cleaner water



CBX OPTICAL SLUDGE BLANKET METER

Cerlic CBX is a reliable stationary sludge blanket meter that detects sedimented or thickened sludge at various positions in waste water treatment plants. The meter may also be used for applications measuring an interface in a floating medium.

Cerlic CBX detects the blanket by means of a near infrared (NIR) suspended solids sensor, which travels through fluff layers until it finds the preset blanket solids concentration. Measuring suspended solids using a transmission method provides a true reading for the sludge content without either colour compensation or indirect assumptions. By combining Cerlic's transmitting suspended solids meter with modern mechanics, the true sludge level can now be obtained without any risk of disruption from such things as floating sludge. Cerlic's CBX may also provide a sludge profile of the media in which fluff layers can be seen. The meter is housed in a stainless steel cabinet for installation in a variety of environments and has automatic flushing of both sensor and cable, which means that maintenance is minimal.

- Optical meter with transmission technology
- Not disrupted by fluff or floating sludge
- Optimisation in thickener and sedimentation pools
- Built in cleaning
- Built in heat

Sludge blanket meter CBX is housed in a stainless steel cabinet with integral heating and fan, and is extremely suitable for installation indoors or out. The suspended solids sensor is equipped with an 11 m cable and has an inductive power supply. The current reading for suspended solids is transmitted using an optical interface. Power supply and signal transfer are thus completely contact-free, which means a long service life and a high degree of reliability.

OPTIMISATION

Thickening

- Higher and more even TS content for outgoing sludge provides positive effects for subsequent treatment
- Lesser volume of sludge for further treatment
- Better reject water reduces internal load and reduce the risk of operational up-sets
- Lower heating costs and longer retention time in the digester provides higher degree of digestion and thus higher gas production
- Reduced sludge quantity results in lower costs for further handling and transportation of the dewatered sludge

Sedimentation

- Early warning of sedimentation problems provides a good indication of plant operation
- Warns and prevents sludge washout, thereby helping to keep to emission requirements
- Option to control capacity of return sludge pumping saves on costs and reduces the risk of pumping sludge with a low TS content
- Higher and more even TS content for return and excess sludge provides better operation of subsequent stages, thickening, for example
- Labour-saving measurement and 24-hour availability

TRANSMISSION

Optical measurement of particle content in liquids is a well-proven method. A beam of light is affected if there is anything in its way; some of the light is scattered when it encounters a particle, while some of it is absorbed. Light that is neither scattered nor absorbed continues straight forward. A transmission meter measures the loss of light from the light passing through the medium and shows the quantity of suspended solids in the

liquid. A transmission meter does not detect particles that are smaller than half the wavelength. This is an advantage when you want to measure suspended solids, as colloidal and other very small particles do not noticeably affect the measurement. Measuring sludge content using a transmission method provides a true reading for the suspended solids content without either colour compensation or indirect assumptions.

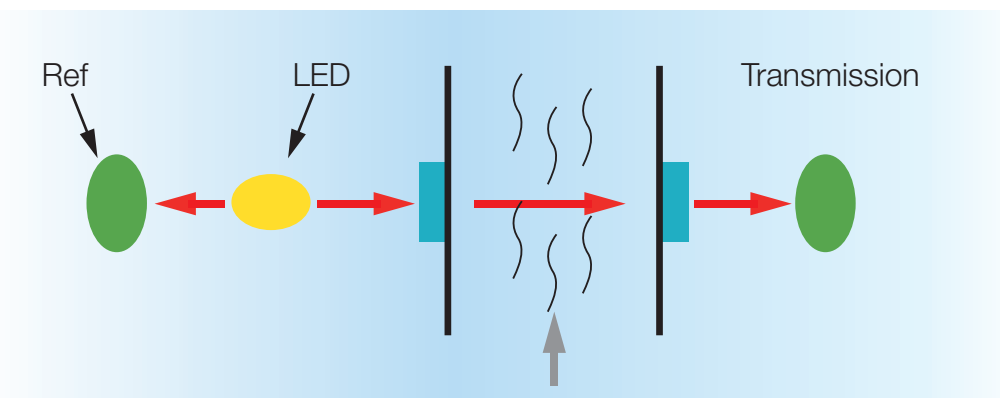

BB2 CENTRAL UNIT

The CBX uses, as well as all Cerlic X-range sensors, the central unit BB2 for measurement of suspended solids, oxygen content, pH, redox potential and flow in municipal and industrial purification plants. Reliable and disruption-proof digital communication takes place between sensor and central unit via RS 485. BB2 handles readings, monitoring, control, diagnostics and settings. BB2 has up to four 4-20 mA output signals and there is a fieldbus module as an option. BB2 is easy to use, with self-instructing menus.



ABOUT CERLIC

Cerlic Controls is a Swedish company established in 1977. Its product range includes meters for sludge content, suspended solids, oxygen, pH/redox level and flow. Cerlic also has products aimed at the paper and pulp industry. The company is ISO 9001 certified. Cerlic helps on a global level to limit emissions into lakes, rivers and

seas, by developing, manufacturing, maintaining and actively marketing measurement and control equipment that makes municipal and industrial processes more efficient. Since 2005 Cerlic has been a wholly-owned subsidiary of the Eletta Group. It is based in Huddinge, where all its development and manufacturing takes place.

Technical specifications

Power Supply	115V / 60Hz (230V / 50Hz)
Power consumption	20VA during measuring cycle 10VA, stand-by 70VA with heater
Flush water supply	1/2" hose nipple
Flush water pressure	Min. 30 psi (2 bar) Max. 90 psi (6 bar)
Enclosure electronics	NEMA 4 (IP55)
Operating temp	-4...+122°F (-20...+50°C)
Weight	44lbs (20 kg) incl. mtg. brkt.
Dimensions w/housing	15.7" x 8.3" x 15.7" H x D x W (400 x 210 x 400 mm)
Outputs	4-20mA (20-4mA) RS485 serial communication Alarm contact (2A, closing)
Inputs, limit switch	Limit switch, N/O, (supplied by customer) (5 VDC voltage loop)
Measuring range	0-26 ft (8 m)
Cable	Shielded 4-wire polyurethane cable, length 36 ft (11 m)
Measuring principle	NIR optical sensor
Sensor Material	316SS, lenses BK7 glass

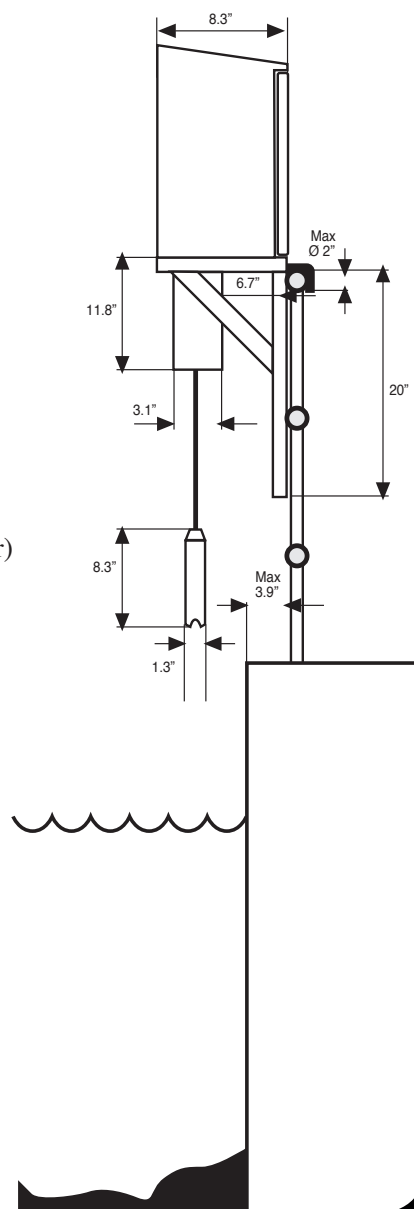
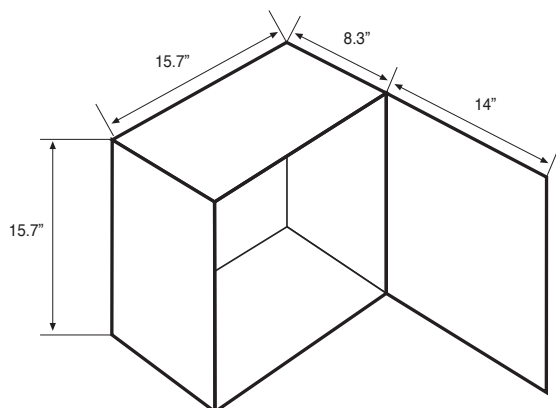

Cerlic
for cleaner water