

Inline Suspended Solids Sensor



- **Wide application range**
 - Monitors suspended solids in RAS, WAS and backwash lines.
- **Low maintenance**
 - Heavy duty stainless steel sensor head
 - Wide 0.59" (15 mm) measuring gap
 - Flushing system with no moving parts

- **Stable measuring principle**
 - Built-in LED compensation loop to alleviate frequent recalibration of sensor
 - Temperature compensation loop
 - Measurement by 880 nm NIR-light
- **Wide measuring range**
 - Min 0 - 100 mg/l
 - Max 0 - 50,000 ppm (mg/l)
 - Depending on type of solids

The ITX-IL In-Line Suspended Solids Sensor is the ultimate tool for effective process control supplied with 1 1/2" SS isolation valve. Designed for up to 87 psig (6 bar) applications with built-in mechanical stop. The sensor is used for continuous measurement of suspended solids in RAS, WAS, MLSS and Sand Filter Backwash monitoring in industrial plants. The measuring

principle is a single beam of pulsed NIR-light. The LED light source pulses at 880 nm. In each installation the meter is calibrated using actual lab tests for up to five sample points. An automatic cleaning system with built-in flushing nozzles ensures accurate measurements with little maintenance.

Technical specifications

Material	316SS (SIS2343)	The sensor is manufactured in stainless steel which limits corrosion. The head of the sensor is designed to achieve the highest self-cleaning effect.
Weight	6.1 lbs (2.8 kg) 6.5 lbs (3 kg)	Sensor Valve Assembly
Connection	33 ft (10 m) Max run Flushing hose	5-pin M12-connector 300 ft (100 m) 5/16" (8 mm) Black PVC, 33' (10 m) long
Process connection	1 1/2" NPT	316 SS Ball valve with 1 1/2" NPT Nipple. EPDM o-rings
Enclosure	NEMA 4 (IP65)	
Process temp.	32 - 140°F (0 - +60°C)	
Pressure rating	87 psig (6 bars)	With automatic cleaning.
Measuring principle	Straight transmission	The detected measuring signal is inversely logarithmical proportional to the suspended solids concentration.
	0.59" (15 mm) gap	BK7 glass lens.
Measuring range	Min 0 - 100 ppm (mg/l) Max 0 - 50,000 ppm (mg/l)	Depending on type of sludge.
	GaAs, Diode 880 nm	ITX-IL measures transmitted light which facilitates a zero-point calibration. At 800 nm no colors can be seen which eliminates a source of error.
Cleaning system	Option	Air or water cleaning at 30 psig (2 bars) over process pressure.
Accessories		Solenoid valve for flushing 120 psig (8 bars). Signal cable 33 ft (10 m).

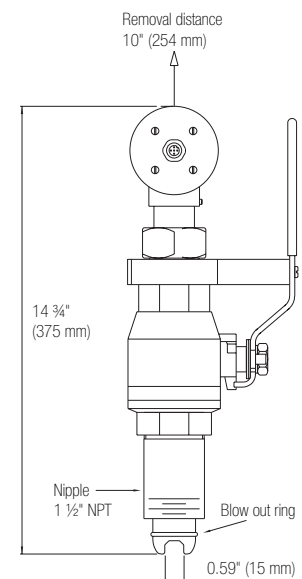

ITX-IL

BB2 Control Box All our sensors in the X-series can be combined and connected to a Control Box; BB2. The BB2 is equipped with the latest in communication protocols for compatibility with a wide array of automation systems. The control box comes with two 4 - 20 mA outputs as standard. It can support up to four

sensors for 4 - 20 mA or Profibus DP output signals. Relay outputs in the BB2 are used for high and low alarms or to provide a pulse for automatic cleaning for sensors with that function. Further information can be found in our leaflet for BB2.